



## COMUNICADO Nº 11-15

20/03/2015

### ÍNDICE

1. NATAÇÃO PURA
2. ÁGUAS ABERTAS
3. NATAÇÃO SINCRONIZADA
4. NATAÇÃO ADAPTADA
5. FORMAÇÃO
6. RECORDES HOMOLOGADOS
7. DIVERSOS

#### 1. NATAÇÃO PURA

##### **a) Campeonatos Nacionais de Juvenis, Juniores, Seniores e Absolutos – Piscina Longa**

Informa-se que no regulamento específico da competição supra, por lapso, no segundo parágrafo do ponto 4. 'Participação', deve ler-se:

*Exceptuam-se as provas de:*

- a) 800 metros Livres Femininos e 1500 metros Livres Masculinos, onde as inscrições serão limitadas às seguintes cotas:

*Juvenis: 20 melhores tempos de inscrição*

*Juniores: 20 melhores tempos de inscrição*

*Seniores: 10 melhores tempos de inscrição*

- b) 1500 metros Livres Femininos e 800 metros Livres Masculinos onde as inscrições serão limitadas aos 30 melhores tempos de inscrição, independentemente da categoria.

##### **b) Dispositivo de partida para provas de Costas.**

Informamos que no decurso do Multinations Youth Meet a realizar em Lisboa – Jamor nos próximos dias 28 e 29 de Março e nos Campeonatos Nacionais Juvenis, Juniores, Seniores e Absolutos – Piscina Longa a disputar em Coimbra de 1 a 4 de Abril, serão utilizados os

\_\_PATROCINADORES\_\_



\_\_PARCEIROS INSTITUCIONAIS\_\_



\_\_PARCEIROS\_\_



Moradia Complexo do Jamor, Estrada da Costa, 1495-688 Cruz Quebrada

+351 21 415 81 90/91

+351 21 419 17 39

secretaria@fpnatacao.pt



dispositivos de partida para as provas de costas. Ver regras FINA SW 6.1 e SW 6.2. Segue em anexo a informação técnica sobre os referidos dispositivos.

### **c) 1<sup>os</sup> Jogos Europeus – Baku 2015 (AZE)**

No seguimento da informação recebida sobre os prazos a cumprir para a Competição supra, informamos que serão considerados todos os resultados oficiais até ao dia 4 de Abril pf., inclusive.

## **2. ÁGUAS ABERTAS**

### **Final do Campeonato Nacional de Longa Distancia, Coimbra, 18 de Abril de 2015**

Junto anexamos a lista dos nadadores apurados para disputar a fase final do Campeonato Nacional de Longa Distância. As inscrições para esta fase decorrem até as 18h00 do dia 6 de Abril de 2015. Após essa data serão classificados os nadadores imediatamente a seguir, de acordo com os critérios definidos no regulamento da competição

## **3. NATAÇÃO SINCRONIZADA**

### **a) Estágio de Preparação da Selecção Nacional Absoluta, 15/18 Abril - Coruche**

Para este Estágio de preparação para o “Open de Espanha” (a realizar de 26 a 28 Junho), estão seleccionadas, as seguintes nadadoras:

<b>Praticante</b>	<b>Clube</b>	<b>Praticante</b>	<b>Clube</b>
Ana Catarina Jesus	OSCN	Diana Sanches Gomes	FOCA
Ana Isabel Baptista	FOCA	Filipa Alexandra Anacleto	AMINATA
Ana Raquel Azevedo	FOCA	Maria do Carmo Martins	AMINATA
Bárbara Nogueira Costa	GESLOURES	Maria Leonor Miranda	GESLOURES
Cheila Morais Vieira	GESLOURES	Maria Margarida Gonçalves	GESLOURES
		Marta Ribeiro Dias	GESLOURES

O enquadramento técnico será assegurado pelos seguintes elementos:

**DTN-NS:** Marta Martins

**Treinadora FPN:** Sandra Montes

**Treinadora Assistente:** Mireia Bravo

PATROCINADORES



PARCEIROS INSTITUCIONAIS



PARCEIROS



Moradia Complexo do Jamor, Estrada da Costa, 1495-688 Cruz Quebrada

+351 21 415 81 90/91

+351 21 419 17 39

secretaria@fpnatacao.pt



**Concentração:** 15 de Abril, na Piscina Municipal de Coruche - 10h30

**Final:** 18 de Abril, na Piscina Municipal de Coruche - 17h00

**Alojamento:** Residência de estudantes da Câmara Municipal de Coruche.

### Informações:

As nadadoras deverão ser portadoras de todo o equipamento necessário aos treinos, quer na água, quer em seco.

Esta convocatória é válida e aplicável somente ao Estágio em epígrafe.

Estão convidadas a assistir aos treinos deste Estágio as treinadoras e juizes de Natacao Sincronizada interessadas, dentro do seguinte período horário: **18 de Abril – das 09h00 às 13h00**

Os pedidos de dispensa ao abrigo do Decretos-Lei nº 272/2009 de 1 de Outubro e, por implicarem requisição ao Instituto Português do Desporto e Juventude terão que ser solicitados previamente à realização deste estágio.

### *b) Estágio de Preparação da Selecção Nacional Juvenil, 23/26 Abril - Coruche*

Para este Estágio de preparação para o “Open de Madrid” (a realizar de 14 e 15 de Junho), estão seleccionadas as seguintes nadadoras:

Praticante	Clube	Praticante	Clube
Ana Beatriz Fernandes	GESLOURES	Mafalda Sousa Mendes	AMINATA
Beatriz Cruz Gama	OSCN	Marta Margarida Costa	OSCN
Carolina Silva Nogueira	GESLOURES	Sofia Inês Guerreiro	AMINATA
Filipa Morgadinho Coelho	GESLOURES	Solange Graça Cardoso	GESLOURES
Francisca Sena Fonseca	GESLOURES	Telma BarrosTeixeira	FOCA
Laura Ribeiro Cunha	FOCA		

A nadadora Mariana Teixeira do clube FOCA está convidada a integrar o estágio durante o dia 26 de Abril entre as 8h00 e as 17h00, mediante responsabilidade de deslocação por parte dos respectivos Encarregados de Educação e/ou Clube.

\_\_PATROCINADORES\_\_



\_\_PARCEIROS INSTITUCIONAIS\_\_



\_\_PARCEIROS\_\_



Moradia Complexo do Jamor, Estrada da Costa, 1495-688 Cruz Quebrada

+351 21 415 81 90/91

+351 21 419 17 39

secretaria@fpnatacao.pt



O enquadramento técnico será assegurado pelos seguintes elementos:

**DTN-NS:** Marta Martins

**Treinadora FPN:** Sandra Montes

**Treinadora Assistente:** Mireia Bravo

**Concentração:** 23 de Abril, na Piscina Municipal de Coruche - 10h30

**Final:** 26 de Abril, na Piscina Municipal de Coruche – 17h00

**Alojamento:** Residência de estudantes da Câmara Municipal de Coruche

### Informações:

As nadadoras deverão ser portadoras de todo o equipamento necessário aos treinos, quer na água, quer em seco.

Esta convocatória é válida e aplicável somente ao Estágio em epígrafe.

Estão convidadas a assistir aos treinos deste Estágio as treinadoras e juizes de Natação Sincronizada interessadas, dentro do seguinte período horário: **25 de Abril – das 16h00 às 19h00**

Os pedidos de dispensa ao abrigo do Decretos-Lei nº 272/2009 de 1 de Outubro e, por implicarem requisição ao Instituto Português do Desporto e Juventude terão que ser solicitados previamente à realização deste estágio.

### *c) 5º Open Make Up Forever, 13 a 15 de Março de 2015, Paris (FRA)*

PROVA	CLASS.	PRATICANTE (S)	PONTUAÇÃO FINAL
<b>28 Duetos Técnicos Participantes</b>			
<b>Dueto Técnico</b>	24º	Bárbara Costa	67.1851
		Ana Isabel Baptista	
		Diana Gomes (R)	
<b>28 Duetos Livres Participantes</b>			
<b>Dueto Junior</b>	24º	Bárbara Costa	68.2333
		Diana Gomes	
		Ana Isabel Baptista (R)	

PATROCINADORES



PARCEIROS INSTITUCIONAIS



PARCEIROS



Morada Complexo do Jamor, Estrada da Costa, 1495-688 Cruz Quebrada

+351 21 415 81 90/91

+351 21 419 17 39

secretaria@fpnatacao.pt



#### 4. NATAÇÃO ADAPTADA

##### **a) Campeonato do Mundo de Natação Adaptada 2015 - Actualização de critérios**

Tendo em conta os critérios de acesso publicados pelo International Paralympic Committee para participação no Campeonato do Mundo de Natação Adaptada 2015 e os Jogos Paralímpicos Rio 2016, informamos que esta entidade fez uma alteração na prova dos 200 metros livres para a classe S2.

Desta forma, e considerando os critérios publicados pela FPN para participação no Mundial de 2015, o mínimo de acesso para a prova citada passa a ser de 5:52.00 (MQS) e o tempo mínimo de acesso é de 6:13.12 (MET).

##### **b) Campeonatos Nacionais de Juvenis, Juniores, Seniores e Absolutos (Coimbra – 1 a 4 de Abril)**

Considerando o exposto no ponto anterior, para os Campeonatos Nacionais de Juvenis, Juniores, Seniores e Absolutos (Coimbra – 1 a 4 de abril) o tempo de acesso para a prova dos 200 metros livres classe S2 passa a ser de 06.02,56.

#### 5. FORMAÇÃO

##### **a) Acção de Formação “Avaliação e Controlo do Treino em Natação”**

Dando continuidade à execução do PAF 2015, vão realizar-se dia 27 de Março pelas 21H00 uma acção de formação com o tema “Avaliação e Controlo do Treino em Natação”. A formação será assegurada pelo formador Dr. Marcus Bernhoeft, médico da Confederação Brasileira de Desporto Aquáticos.

A Acção está limitada às primeiras 30 inscrições. Não confere UC para efeitos de renovação do TPTD.

Mais informações em <http://www.fpnatacao.pt/forma%C3%A7%C3%A3o/1426759096-acao-de-formacao-avaliacao-e-controlo-do-treino-em-natacao> e no flyer em anexo.

##### **b) Acções de Formação de Natação Pura “A Importância no Rendimento Desportivo em Natação Pura” e “Planeamento do Treino em Natação Pura”**

Dando continuidade à execução do PAF 2015, vão realizar-se no decorrer dos Campeonatos Nacionais de Juvenis, Juniores, Seniores e Absolutos de piscina longa duas acções de formação dias 2 e 3 de Abril com abordagens aos seguintes temas “A Importância no Rendimento Desportivo em Natação Pura” e “Planeamento do Treino em Natação Pura”. As acções serão asseguradas respectivamente pelos formadores Andrew Jones, Director da

PATROCINADORES



PARCEIROS INSTITUCIONAIS



PARCEIROS



Moradia Complexo do Jamor, Estrada da Costa, 1495-688 Cruz Quebrada

+351 21 415 81 90/91

+351 21 419 17 39

secretaria@fpnatacao.pt



Faculdade de Desporto e Ciências da Saúde, da Universidade de Exeter, UK e José Silva, Treinador principal do Futebol Clube do Porto.

Cada acção confere 1UC para efeitos de renovação do TPTD.

Mais informações em <http://www.fpnatacao.pt/forma%C3%A7%C3%A3o/1426345058-acoes-de-formacao-natacao-pura> e no flyer em anexo.

**c) Curso de Arbitragem de Natação Adaptada – Vila Franca de Xira – 21/22 Fev.**

**APTOS**

Alda Maria Pascoal Sargento	Joaquim da Silva Crespo
Ana Paula Dias Jesus	José Arruda
Ana Paula Garcia	Lara Sofia Nascimento Palmeira
Andreia Sofia Câmara Abreu	Maria Clara Crespo
António Luís Madeira Neves	Maria José Ferreira
Artur Jorge Pereira de Castro	Mário Nunes
Catarina Silva	Pedro Carvalho
Filipa Gonçalves	Pedro Cruz
Graça Maria Cardoso Vilarinho	Rosa Maria Onofre Ramos
Ilídio José Augusto de Jesus	Rosário Lima
Isabel Alexandra Balreira Guerra	Ruben Iuri Oliveira
Isabel Resende	Tânia Sofia Guimarães Barros
Jan Gin Quon	Vitor Santiago
João Luís do Amaral Teixeira	

**d) Curso Elementar de Arbitragem Natação Pura – ARNN Nov 2014**

**APTOS**

Ana Catarina Gomes Rodrigues	Inês Catarina Garcia Ribeiro
Ana Manuela Carvalho Dias	Inês Margarida Figueiredo Bernardo
Anabela Silva Possacos	Maria Patrocínia Correia Ferreira S. Correia

PATROCINADORES



PARCEIROS INSTITUCIONAIS



PARCEIROS



Moradia Complexo do Jamor, Estrada da Costa, 1495-688 Cruz Quebrada

+351 21 415 81 90/91

+351 21 419 17 39

secretaria@fpnatacao.pt





André António Dias de Carvalho	Nuno Miguel Barroso Fernandes
Cláudio Miguel Martins Pereira	Patrícia Alexandra Curado Quintas D. Poeta
Débora Catarina Mota Ferreira	Rafael Augusto Costa Sobrinho Correia
Francisco José dos Santos Valfreixo	

**e) Curso Elementar de Arbitragem Natação Pura – Complemento de Águas Abertas – ARNN Nov 2014**

**APTOS**

Daniel Pinto Conceição	Raquel da Silva Marinho
Fábio Gonçalves Ferreira	Verónica Conceição Dias Lei
Marco Aurélio Pinto Baptista	

**6. RECORDES HOMOLOGADOS**

**a) Natação Pura**

RECORDES NACIONAIS – Pisc. 25m					
DATA	PROVA / CTG.	PRATICANTE	TEMPO	CLUBE	LOCAL
14/03/15	1500 L INF B-12	Mafalda Sofia Rosa	18:28.43	CNRM	Coruche

RECORDES NACIONAIS – Pisc. 50m					
DATA	PROVA / CTG.	PRATICANTE	TEMPO	CLUBE	LOCAL
14/03/15	4x100 L-C JUV	Marta Alexandra Canedo	04:10.55	FCP	Póvoa Varzim
		Maria Francisca Cabral			
		Joana Martins Pereira			
		Ana Rita Faria			

**b) Masters**

Em anexo, Recordes Homologados, obtidos no III Torneio Masters do Litoral Alentejano, que decorreu em Sines, no dia 7 de Março 2015.

\_\_PATROCINADORES\_\_



\_\_PARCEIROS INSTITUCIONAIS\_\_



\_\_PARCEIROS\_\_



Morada Complexo do Jamor, Estrada da Costa, 1495-688 Cruz Quebrada

+351 21 415 81 90/91

+351 21 419 17 39

secretaria@fpnatacao.pt



## 7. DIVERSOS

### **Formação de Treinadores: Desenvolvimento da Aprendizagem e Identidade do Treinador de Desporto**

Realiza-se nos próximos dias 21 e 22 de Abril na Faculdade de Desporto da Universidade do Porto o seminário intitulado “Formação de treinadores: desenvolvimento da aprendizagem e identidade do treinador de desporto”, no qual serão abordados novos modelos e estratégias de formação.

A acção é acreditada pelo IPDJ no âmbito da formação geral de treinadores.

Mais informações em <http://events.fade.up.pt/seminarioft2015/>

Pela FPN

António José Silva  
Presidente

PARCEIROS



geração em movimento

PARCEIROS INSTITUCIONAIS



INSTITUTO PORTUGUÊS DO DESPORTO

EXERCÍCIOS FÍSICOS

PARCEIROS



Morada Complexo do Jamor, Estrada da Costa, 1495-688 Cruz Quebrada

+351 21 415 81 90/91

+351 21 419 17 39

secretaria@fpnatacao.pt





# ACÇÃO DE FORMAÇÃO

## Avaliação e Controlo do Treino em Natação



### FORMADOR

**DR. MARCUS BERNHOEFT**

MÉDICO DA CONFEDERAÇÃO BRASILEIRA DE DESPORTOS AQUÁTICOS

HOTEL RIVIERA—CARCAVELOS  
27 DE MARÇO SEXTA—FEIRA  
INÍCIO: 21H00



INSTITUTO PORTUGUÊS  
DO DESPORTO  
E JUVENTUDE, I. P.



**FPN**  
FEDERAÇÃO PORTUGUESA DE NATAÇÃO



FORMAÇÃO

### TAXA DE INSCRIÇÃO

Gratuito. Limitado às 30 primeiras inscrições

(Não confere UC para efeitos de Renovação do Título de Treinador)

Faça a sua inscrição na Federação Portuguesa de Natação

[www.fpnatacao.pt](http://www.fpnatacao.pt)



# AÇÕES DE FORMAÇÃO

## A IMPORTÂNCIA DA NUTRIÇÃO NO RENDIMENTO DESPORTIVO EM NATAÇÃO

### PLANEAMENTO DO TREINO EM NATAÇÃO PURA



## FORMADORES

### ANDREW JONES

(A IMPORTÂNCIA DA NUTRIÇÃO NO RENDIMENTO DESPORTIVO EM NATAÇÃO—2 DE ABRIL 21H00)

DIRETOR DA FACULDADE DE DESPORTO E CIÊNCIAS DA SAÚDE, DA UNIVERSIDADE DE EXETER, UK  
COORDENADOR DO GRUPO DE INVESTIGAÇÃO EM BIONERGÉTICO E PERFORMANCE HUMANA  
CONSULTOR NA ÁREA DA FISIOLÓGIA E NUTRIÇÃO DO INSTITUTO INGLÊS DO DESPORTO

### JOSÉ SILVA

(PLANEAMENTO DO TREINO EM NATAÇÃO PURA—3 DE ABRIL 21H00)

TREINADOR PRINCIPAL DO FUTEBOL CLUBE DO PORTO  
TREINADOR DE ALTO RENDIMENTO NATAÇÃO PURA



INSTITUTO PORTUGUÊS  
DO DESPORTO  
E JUVENTUDE, I. P.



FEDERAÇÃO PORTUGUESA DE NATAÇÃO



FORMAÇÃO



COMPLEXO  
OLÍMPICO  
DE PISCINAS

COMPLEXO DE PISCINAS DE COIMBRA

## DESTINATÁRIOS / TAXA DE INSCRIÇÃO

Treinadores de Grau II, III e IV de NPD Filiados na FPN: | 1 ação: 12,50€ | 2 ações: 20,00€

Treinadores de Grau I | Treinadores não Filiados | Outros Interessados | 1 ação: 25,00€ | 2 ações: 40,00€

(Cada ação confere 1 UC para efeitos de renovação do TPTD Grau II, III e IV)

Faça a sua inscrição na Federação Portuguesa de Natação até **30 de Março**

(<http://www.fpnatacao.pt/forma%C3%A7%C3%A3o/1426345058-aco-es-de-formacao-natacao-pura>)

## 1 INTRODUCTION

The Omega Backstroke Ledge (OBL1) is the ideal complement to the Omega Starting Blocks OSB11, OSB12 and OSB14 for the backstroke swimming. This device has been fully developed according to the FINA rules (handbook 2013 – 2017). OBL1 allows the best starts for backstroke swimming competitions of all levels and categories.

**Simply/easily mounted:** it can be used during the entrance in the water and once the race has begun it can be removed not to bother the swimmers during the competition.

**Help psychologically the backstroke swimmer:** this new device gives swimmers the assurance they did not have before when entering the water. This takes away pressure before starting the competition thanks to the anti-skid surface that covers the grip mechanism of grasp. It allows a better grasp to the backstroke swimmers when entering the water.

**Adjustable according to the swimmer's size:** the aptitude to regulate the length of the Backstroke Start is an advantage to bear in mind, since not all backstroke swimmers have the same size.

**Better power and force when entering the water:** thanks to the Backstroke Start, the swimmers gain in power and force when entering the water. Through the training with this device, swimmers gain confidence and perform better.

You now have the opportunity to improve your backstroke swimming performance. See for yourself how many milliseconds you can gain at the start!

Please read this manual carefully before starting to use your **Backstroke Ledge**.

## 2 PRECAUTIONS AND WARNING

### 2.1 Before using the Backstroke Ledge

Always check the unit to verify the full integrity of all the parts. If a single component is broken, gets loose or shows cracks, **DO NOT USE** the device.

### 2.2 Using the Backstroke Ledge

You must train a lot before each competition to progressively acquire all the skills to control your backstroke start. Before each start, always make sure that there are no obstacles that you might hit. Consider that with the Backstroke Ledge your starting jump is much longer than usual.

All the components of this unit are designed with the utmost care for the safety of all the users (no burrs, no sharp edges, etc.) but ultimately the most relevant factor is your own attention.

Never use the Backstroke Ledge for any sport, activity or task this product is not designed for. Only the proper use of the Backstroke Ledge is described in this manual. Do not leave this product to unsupervised children. Do not expose the backstroke Ledge to fire or to high temperature sources (e.g. do not lay the product on a radiator to dry).

To preserve the device, do not use aggressive cleaners or solvents (e.g. Acetone) which could damage the surface of the ABS components. Refer to chapter 8 (STORAGE AND MAINTENANCE) for details.



### 2.3 Safety rule for Backstroke Ledge

Improper use of Backstroke Ledge could damage it.

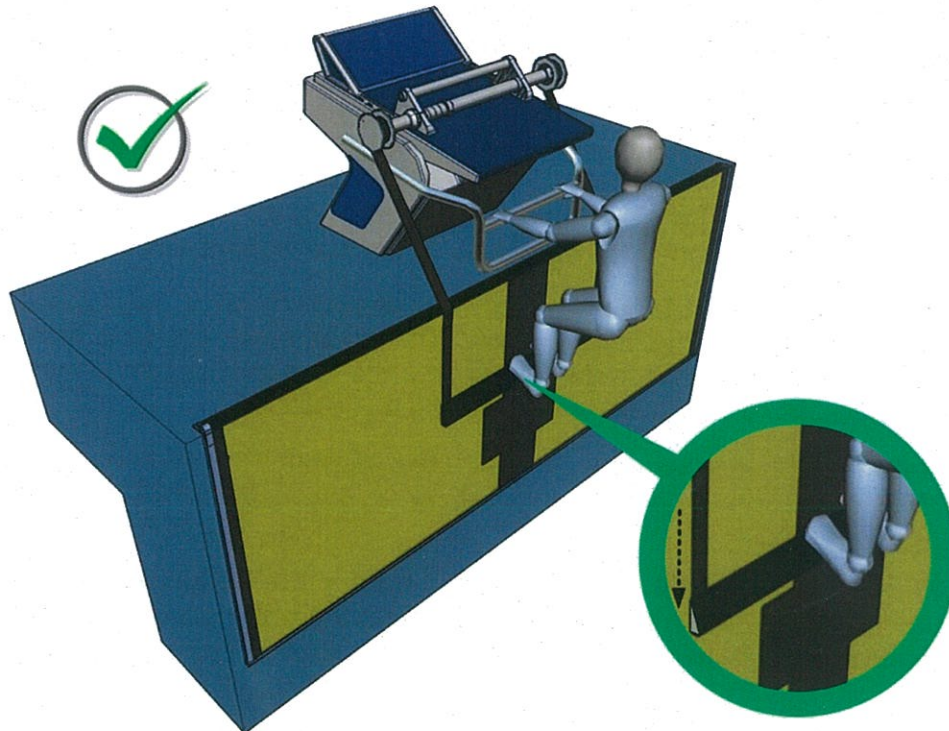

Never put pressure on the Backstroke Ledge when it is in a 90° position.

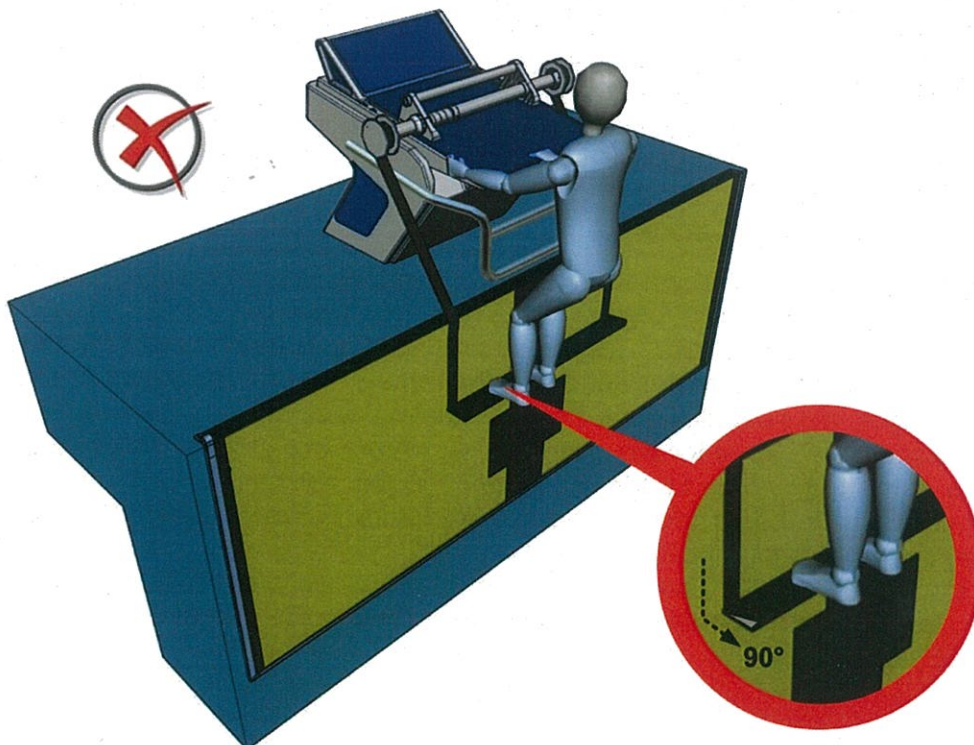



### 3 PRODUCT DESCRIPTION

The Backstroke Ledge is fully compatible with Omega OSB11, OSB12 and OSB14 (  Facilities rules / FR2.7 / “**The height of the platform above the water surface shall be from 0.5 metre to 0.75 metre**”). You have received a product fully assembled and ready to use once unpackaged. Each unit consists of a lower part (which must lean against the end wall of the pool) including a footrest designed to support the swimmer’s push at the start and an upper part to hook the assembly to the starting platform. The upper part also includes a rotating mechanism (Patent Pending) to set the unit to your own starting position and to your size. A return spring allows a “one hand” easy adjustment, also for the athlete in water. The upper handlebar allows an easy grab of the unit for a quick removal after the start.

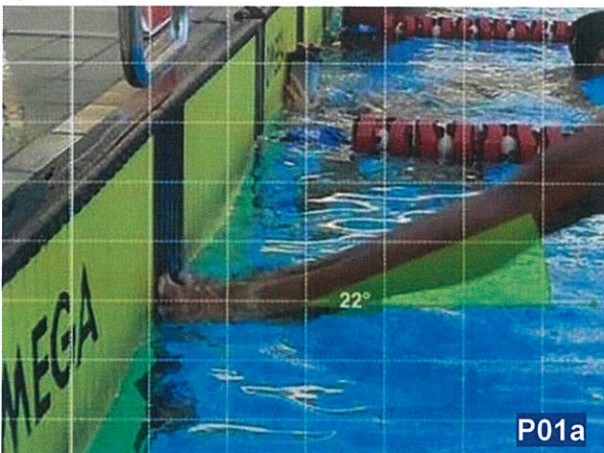

Without Backstroke Start

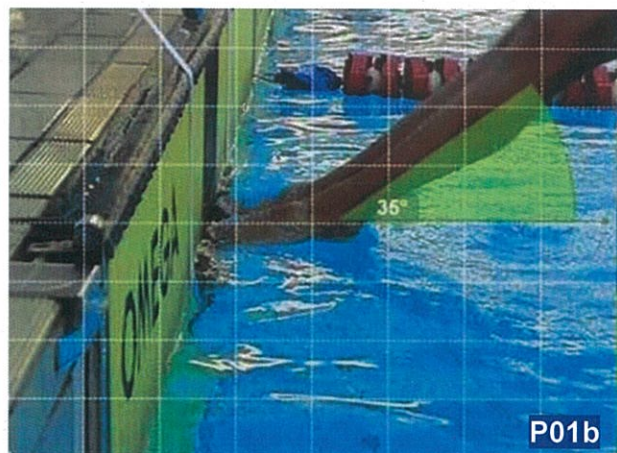

With Backstroke Start

Using this device, the angle between the legs and the water surface during the final push off the wall is greater. As a result, the swimmer’s feet travel the path during the start phase of flight with less contact with the water.

#### 3.1 Components description

- 1 Footrest**
- 2 Straps**
- 3 Rims**
- 4 Bars the unit.**
- 5 Supports**
- 6 Pads**
- 7 Adjustment ring**
- 8 Spring**
- 9 Locking ring**

#### Other components

- Metric hexagonal Allen key N°4 **P05**
- Safety clasp (Chapter 5 / Picture **P11**) **P06**

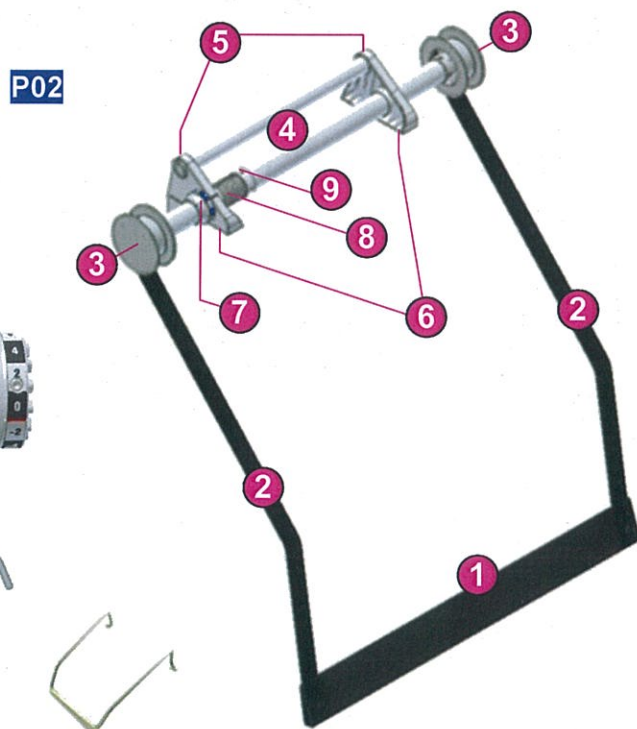



#### 4 FINA – HOW TO USE

- At the start, the toes of both feet must be in contact with the end wall or face of the touchpad. Bending the toes over the top of the touchpad is prohibited.



- The ledge may be adjustable to 4 cm above or 4 cm below the water level.
- The ledge is a minimum of 65 cm in length.
- The ledge must be 8 cm in height, 2 cm at the width with 10 degrees of slope.





## CAMPEONATO NACIONAL DE LONGA DISTANCIA 2015

### NADADORES APURADOS PARA A FINAL

#### Prova 1 – 3000m Livres Masculinos Juvenis B

Diogo Dantas	SCP
Diogo Nunes	CFP
Sérgio Travanca	CFP
Bernardo Barradas	CAC
Sérgio Dias	CAP
Diogo Bastos	CFP
Filipe Santo	SCP
Pedro Ferreira	CNMC
João Fernandes	CDSR
Nuno Sousa	CFP

**Suplentes** – Daniel Nogueira (ANAM) e David Lima (CFV)

#### Prova 2 – 5000m Livres Femininos Juvenis A/Juniores/Seniores

Florbela Machado	ASSSCC
Angélica André	CFP
Vânia Neves	LSC
Beatriz Ranito	SCP
Maria Dias	SCNS
Mariana Ângelo	AAC
Catarina Mestre	SCP
Inês Santos	SFUAP
Mariana Ramos	SCP
Ana Reis	CNAC

PARCINADORES



PARCEIROS INSTITUCIONAIS



PARCEIROS



Moradia Complexo do Jamor, Estrada da Costa, 1495-688 Cruz Quebrada

+351 21 415 81 90/91

+351 21 419 17 39

secretaria@fpnatacao.pt



**Suplentes** – Inês Ferreira (CNMC), Rafaela Oliveira (CFV), Margarida Ribeiro (GESLOURES), Marina Sequeira (SFUAP), Carolina Santos (ANAM), Maria Fernandes (CFV)

### Prova 3- 3000m Livres Femininos Juvenis B

Raquel Tremeço	SCP
Inês Martins	CFP
Raquel Sousa	CFB
Joana Henriques	CAC
Mariana Correia	SCP
Ana Branco	SCP
Julia Fraga	CAP
Mariana Galacha	SCP

### Prova 4 – 5000m Livres Masculinos Juvenis B/Juniores/Seniores

Tiago Oliveira	LSC
Rafael Gil	ANAM
Guilherme Pina	BSCN
Alexandre Coutinho	ASSSCC
Vasco Gaspar	SFUAP
João Gil	ANAM
Tiago Costa	SCP
Tiago Campos	SCNS
Tiago Carvalho	AAC
João Nunes	CFB

**Suplentes** – Francisco Machado (CNAC), Ricardo Ribeiro (CFP), Diogo Marques (ASSSCC), Alexandre Carvalho (CFP), Mário Bonança (SCP), Rui Faria (GDNVNF)

PATROCINADORES



PARCEIROS INSTITUCIONAIS



PARCEIROS



Morada Complexo do Jamor, Estrada da Costa, 1495-688 Cruz Quebrada

+351 21 415 81 90/91

+351 21 419 17 39

secretaria@fpnatacao.pt

Recordes Batidos por Prova

Todas as provas

**Masc., 50m Livres**

12. Série 5 Alberto Vaz Correia 55 SAD 31.07 RN H(60-64) H

**Masc., 50m Mariposa**

6. Série 2 Orlando Gomes Bairrada 45 SAD 41.76 RN J(70-74) J

**Femin., 50m Livres**

11. Série 2 Isabel Maria Raimundo 40 SAD 52.08 RN K(75-79) K

**Femin., 200m Livres**

3. Série 2 Ana Maria Ferreira 50 SAD 3:08.86 RN I(65-69) I

**Femin., 400m Livres**

3. Série 2 Ana Maria Ferreira 50 SAD 6:23.09 RN I(65-69) I

**Femin., 50m Costas**

13. Série 1 Ana Maria Ferreira 50 SAD 50.81 RN I(65-69) I

**Femin., 100m Costas**

13. Série 1 Ana Maria Ferreira 50 SAD 1:45.77 RN I(65-69) I

**Femin., 50m Bruços**

17. Série 1 Ana Maria Ferreira 50 SAD 55.80 RN I(65-69) I